

NAT520

Zwei-Turm-Kletteranlage "Amazonas"



"Amazonas" ist eine anspruchsvolle Kletteranlage mit einer Röhrenrutsche und dem phantasievollen Entdecker-Thema. Die Anlage unterstützt die Beweglichkeit, Gleichgewicht und Koordination des Kindes.

Gruppe	KLASSISCHES SPIEL
Kategorie	Klettergeräte & Netze
Optimales Alter der Nutzer	4 - 12
Max. freie Fallhöhe (cm)	287
Gerätehöhe (cm)	545
Fallraum	47.6 m2



CLIMB



SOCIALIZE



SLIDE



SUR-
FACE

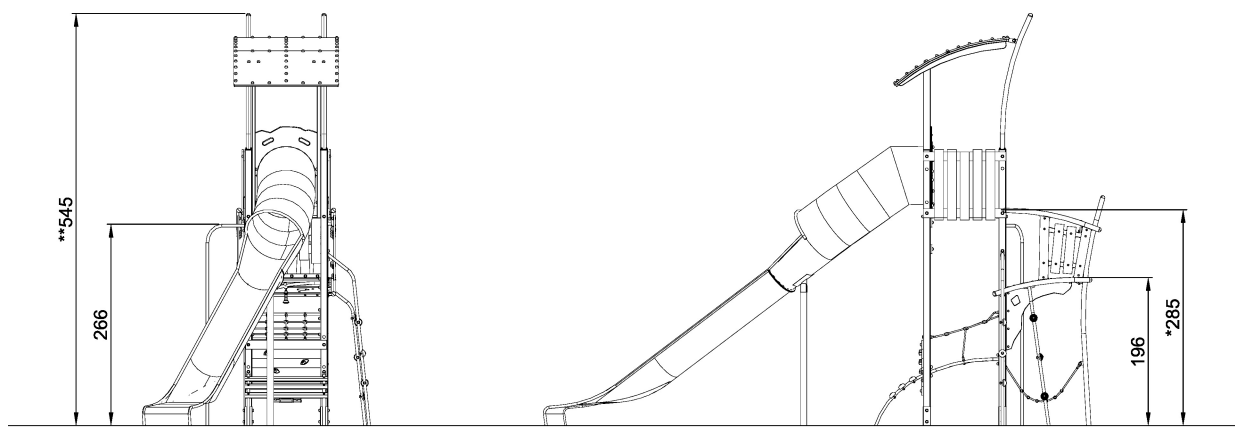
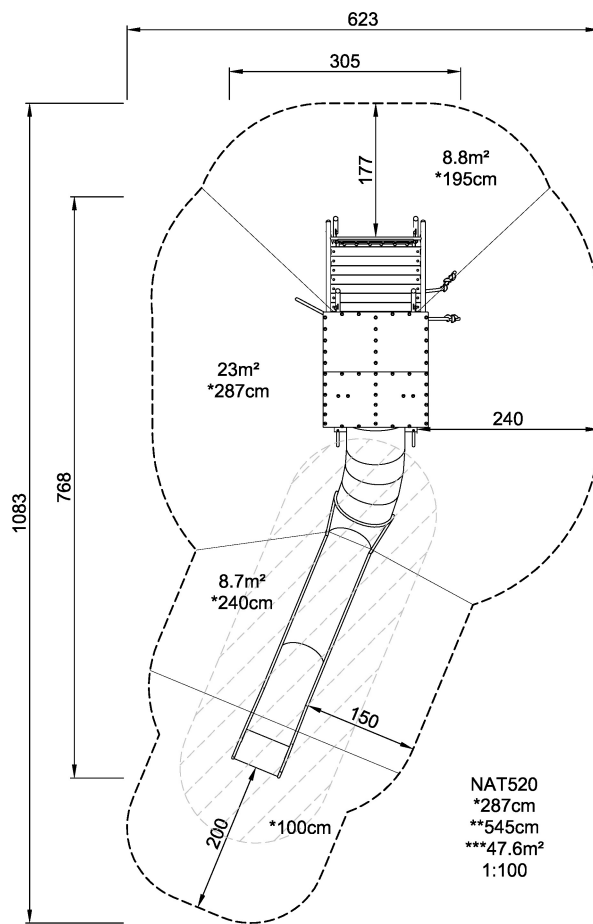

NAT520
1:100

* = Max. freie Fallhöhe.
** = Gesamthöhe des Gerätes.

Gewicht / schwerstes Teil	kg.	Montage (Arbeitskräfte)	Person(en)
Benötigter Beton	NaN m3	Montage (Arbeitsstunden)	Std.
Anzahl Fundamente	NaN	Aushub	NaN m3